



Keith Louis Enterprises & Innovations (KLEI)

Phone: +61 (0) 406614044

Email: KLE.Innovations@gmail.com

Skype: EichersKL

www.KLEInnovations.com

KLEI™QSeries Cables TECHNICAL SUMMARY

The next generation Express, Essence, Quiescence, and GZSeries cables by Keith Louis (KL)

The KLEI™QSeries cables -- QFLOW™ and QPURITY™ -- take the highly acclaimed original Eichmann Express, Essence, Quiescence, and KLEI GZSeries cables to a new level of performance and sophistication.

They offer a new approach and significant design enhancements.

The architecture/technology utilised in KLEI™QSeries cables reflects the cumulative and progressive engineering of the prior Eichmann Ratio™, GNC™, gZero™, gZEROS™, gPOWER™, zFlow™, zPurity™, and current QFLOW™, QPURITY™ architectures/technologies. As such we have decided to group them into one cumulative and progressive trademark name, that being QZERO™.

The QZERO™ architecture/technology strives to maintain a Quiescent/Quiescence™ zero state, where like the GZSeries™ architectures/technologies, dynamically works to further, and even more effectively, maintain a zero voltage Low Noise/Ground state. It is utilised and implemented, in a manner...

- to further dynamically enhance electron flow in the Signal conductor.
- to further protect the Signal from capacitive, inductive, EMF, EF, EFI, RF, static charges, and other effects.
- to further facilitate a smooth uninterrupted signal flow from one component to another, effectively isolating and allowing them to perform their task without interference.

History

KLEI cables are the result of over thirty-five years of dedicated research by designer Keith Louis.

They represent the logical extension of his work on the interaction between ground and signal carrying conductors, and elevate the concepts behind the patented Eichmann Ratio™ to a new level. In his earlier Quiescence designs at ETI, passive Ground Nulling Circuitry (GnC™) was employed to reduce and control the effects of the ground on the signal conductor, and to simultaneously use the ground to protect it from external interferences such as EFI, EMF, RF, and static charges. With KLEI, he has further refined and advanced the Eichmann Ratio™ and GnC™ technology, with the gZero™, gZEROS™, zFlow™, and zPurity™ technology, as utilised in the KLEI GZSeries cables.

KLEI's QSeries cables not only refine and advance this technology, but take a quantum leap beyond the earlier, and at the time, radical and ground-breaking Quiescence designs -- all the result of additional years of dedication, experimentation, measurement, listening, mathematical modelling, and new understandings of recent advances in processes and conductivity.

Cable manufacturers industry-wide essentially have the same stated goals. Most feel that a key aspect in reaching these goals relates to how inductive and capacitive reactances are dealt with. They spend development time and money addressing issues of capacitance and inductance in cables, and--using language from their literature--by 'controlling', 'balancing', or 'reducing' one or both. They build their marketing and technical stories around whichever approach they have taken; they write about it at length, and emphasize the uniqueness of their design direction.

All invariably focus on the signal carrying conductor, and manipulate variables such as the size and shape of the conductor, its configuration, the conductivity of various materials, the purity of the conductor, the kind and quality of the dielectric. Some even place networks in the signal path to compensate.

In stark contrast to these approaches, Keith Louis's research produced a proprietary technology which actively works to maintain a quiescent zero Voltage state across the ground, protecting the signal conductor from ground induced capacitance and inductance. This facilitates smooth uninterrupted signal flow from one component to another, which effectively isolates them and allows them to perform their tasks without interference.



QSeries Cables – ICs/SCs/Digital – Architecture/Technology

So, what happens when a component's output is connected to another component's input via interconnecting cables? The component circuit diagram shows that the signal/red and the neutral/black, ie. ground/return, are connecting quite different circuits.

Looking at the electrical roles, that the two conductors play, shows quite clearly that not only can they be different lengths but they can be made from different materials and gauges. The two conductors, though, are in close proximity to each other, so as the electrical energy flows through the signal conductor noise is induced into neutral conductor and vice versa. If coupling feedback effects, ie induction processes, occur between the signal and neutral conductors due to electrical noise, capacitive and inductive reactive effects, impedance interaction effects, and/or ground flow issues then an impeded *effective signal flow* will result.

Because there are two amplifiers channels operating in a stereo system, the induction processes, per channel, will not be exactly the same. This can further result in subtle changes to the phase of the two LR channel signals. Changes in phase tend to alter the stereo image such that the image becomes *smear*ed and/or *unfoc*used.

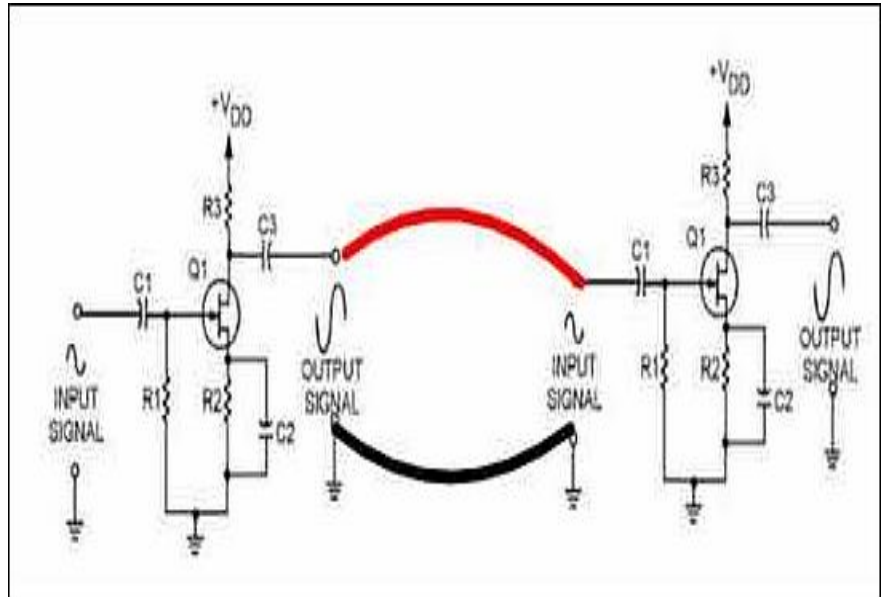

Effective Signal Flow

Cables that affect the efficiency of *effective signal flow* will cause audio components to not perform to their *potential* and the result will cause amplified signal distortions and noise to be introduced and as such affect stereo image and various aspects of sonic reproduction.

Cables that provide *effective signal flow* will allow all audio components to perform to a significantly higher level, that is to their designed potential and perhaps even assist them to exceed their designed potential.

Although there is no flow of electrons, as such, because they simply shuffle back and forth, there is a transfer of electrical energy which flows in one direction from the sending component's output to the receiving component's input. This directional *effective signal flow* through the connecting cable is critical to an audio component's performance.

This is why your ICs (interconnects) or SCs (speaker cables) are important.

How do the KLEI QSeries cables support *effective signal flow*...

1. The signal and neutral (ground/return) conductors have been designed in accordance with the QZERO™ architecture/technology, which act to control and reduce the effectiveness of the induction processes.
2. The neutral is placed around the signal conductor in accordance with the QZERO™ architecture/technology which even further act to control and reduce the effectiveness of the induction processes.
3. Re: Induction Processes – capacitive, inductive, conductive/reactive coupling effects, refer to the following white paper... [Electromagnetic Interference - Considerations in Structured Cabling Systems](#)

QSeries Cables – AC Power Cable - AC/PC – Architecture/Technology

The KLEI QZERO™ architecture/technology take the highly acclaimed original Eichmann Fractal Resonance AC Enhancing architecture/technology to a new level of performance and sophistication. They offer a new approach and significant design enhancements.

So, what happens inside the amplifier when the dynamic voltage and current peaks cannot be accommodated, and the power supply cannot supply the required voltage and current to amplify the signal to the required level? The answer inevitably is that the voltage and current within the circuit will fluctuate and pulse ever so slightly.

These fluctuations and pulses can result in circuit oscillations and ringing which introduce distortions and noise to the amplified signal. Because there are separate amplifier circuits operating in a two-channel system, the fluctuations and pulses per channel will not be exactly the same. This can further result in subtle changes to the phase of the two (LR) channel signals. Changes in phase tend to alter the stereo image such that the image becomes "smear"ed or "unfoc"used".

Effective Supply

In esoteric amplifiers, the power supplies tend to be designed to be very efficient and provide extra headroom. Often, that's why they sound better. Headroom provides extra power supply capacity to meet amplified voltage and current signal peaks. Connecting a power cable that affects the efficiency of the *effective supply* to a power supply will cause an amplifier to not perform to its potential, and the resulting fluctuations and pulses will cause amplified signal distortions and noise to be introduced, and as such, affect stereo image and various aspects of sonic reproduction.,

While power supplies may be designed with sufficient headroom, a power cable can impede *effective supply* to a power supply and in so doing interfere with a power supply's ability to provide *effective supply* to the circuitry. This can cause voltage and current fluctuations and pulses as described above, which cause circuit oscillations and ringing, and introduce distortions and noise to the amplified signal.

A power cable that provides *effective supply* will allow all audio components to perform to a significantly higher level--that is, to their designed potential, and perhaps to even exceed their designed potential.

A mistake often made is equating the flow of electricity to the flow of water through a hose, which is not the case. AC stands for alternating current, but it is also alternating voltage. The voltage is a sine wave that cycles to +120v/240v and -120/240v either side of a zero voltage point at 50/60 cycles a second.

When a circuit is completed by turning on a switch electrical energy is transferred; and then loosely coupled valence electrons in the power cable shift in one direction for one half of the cycle and as the voltage enters the other half of the cycle, the valence electrons shift in the other direction. There is no steady flow of electrons, as such, as they simply shuffle back and forth; but there is a transfer of electrical energy which flows in one direction to the power supply. This directional electrical energy, or *effective supply* of electrical energy through the power cable to the power supply, is critical to an audio component's performance.

That is why your 1.0m or 1.5m power cable is important.

Power cable design needs to consider that there are two conductive wires, i.e., the live and neutral conductors. As the electrical energy flows through the live conductor, noise is induced into neutral and ground conductors, and vice versa. The ground conductor is not usually an issue since it goes directly to ground, and is usually only connected to the component's chassis as a safety consideration. If coupling feedback effects, i.e., induction processes, occur between the live and neutral conductors due to electrical noise, fluctuations, and pulsing, then an impeded *effective supply* to a power supply will result.

How the KLEI AC power cables support *effective supply*...

1. The live and neutral conductors have been designed, in accordance with the Eichmann Ratio architecture, which acts to control and reduce the effectiveness of the induction processes.
2. The neutral is constructed and placed with the live conductor(s), in accordance with the gPOWER™ and zPURITY™ architectures, which acts to further control and reduce the effectiveness of the induction processes.
3. The earth is constructed and placed with the live and neutral conductor(s), in accordance with the gPOWER™, zPURITY™, and QPURITY™ architecture, which acts to even further control and reduce the effectiveness of the induction processes.
4. Re: Induction processes – capacitive, inductive, conductive/reactive coupling effects, refer to the following white paper... [Electromagnetic Interference - Considerations in Structured Cabling Systems](#)

KLEI QZERO™ Architecture/Technology

The KLEI QZERO™ architecture/technology is an exceptionally noiseless technology and we have applied this technology to all KLEI™ QSeries cables, resulting in a level of fidelity you probably thought could only be attained by having components costing considerably more. We believe that the most noticeable improvements are the exceptionally revealing harmonics associated with venue acoustics, that is the echoes and reverberations that surround each artist and instrument. Other attributes that are clearly audible include clarity, neutrality, dynamic performance, bass depth and control, and phasing.

When you connect speakers out of phase the image becomes muddled and the bass performance drops off. Varying the phase by small amounts can move the position of instruments and artists within the image. Inductive noise impacts the phase of the signals of both channels differently, resulting in an inaccurate image. Phase appears to control the placement of instruments and artists in two ways.

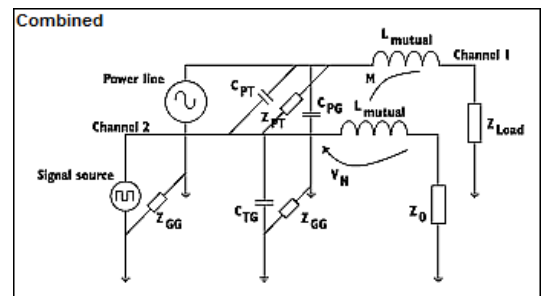
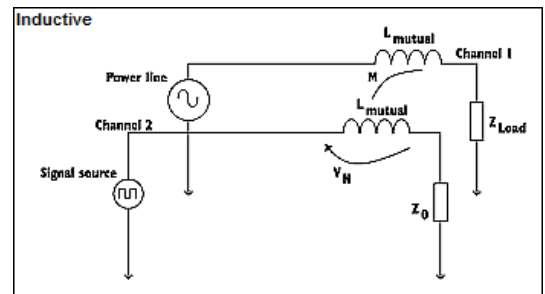
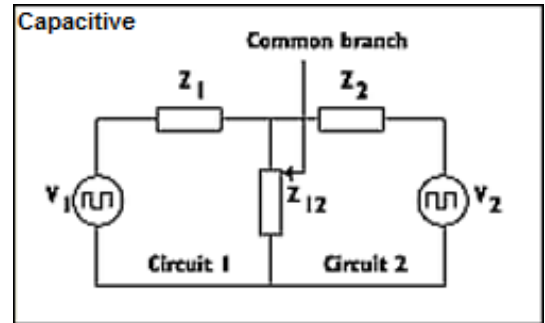
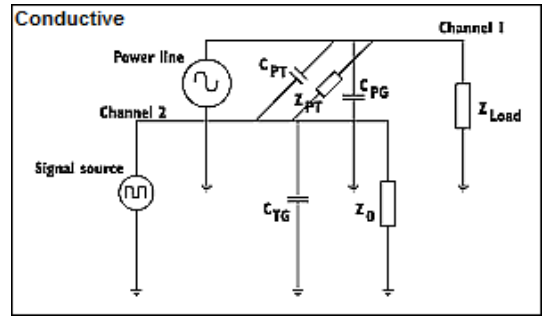

1. Their location within the depth of the image
2. Their location outside the width of the speakers

Since the KLEI technology controls, and even eliminates, the noise within the interconnecting cable, you will notice an incredibly precise placement of instrument and artist within the image and an incredibly large image that melts and fills the boundaries of the listening room.

Please note that your audio system will probably not achieve its full potential by installing just one set of KLEI cables, so it is best that the KLEI technology cables are installed throughout your audio system.



Keith Louis Enterprises & Innovations (KLEI)

Phone: +61 (0) 406614044

Email: KLE.Innovations@gmail.com

Skype: EichersKL

www.KLEInnovations.com